

ACS

Quantum ACS System
Integrated Automation Control System



System Overview

Rely on the leading industry solution that is ready for your toughest job. Nidec Vamco's Quantum Integrated Automation Control System (ACS) combines our best high-speed feed equipment with our signature intelligence system, giving you increased tool life, job adaptability and quality, while reducing tool crashes and downtime.

Quantum Total Intelligence System

The Quantum Integrated Automation Control System provides proven management over material handling, feeding, stacking and motor core rotation processes. Founded on our patented Quantum Feed Intelligence, each system component is designed for performance and process efficiency.

- Operator friendly HMI system
- Coordinated system servo control
- Higher production speeds
- Reduced setup-time
- Consolidated controllers
- Reduced required floor space
- Reduced total system expense



1 Quantum Active Loop Control delivers reduced material acceleration in coordination with feed roll motion to reduce loop whip while increasing production speeds and accuracy.

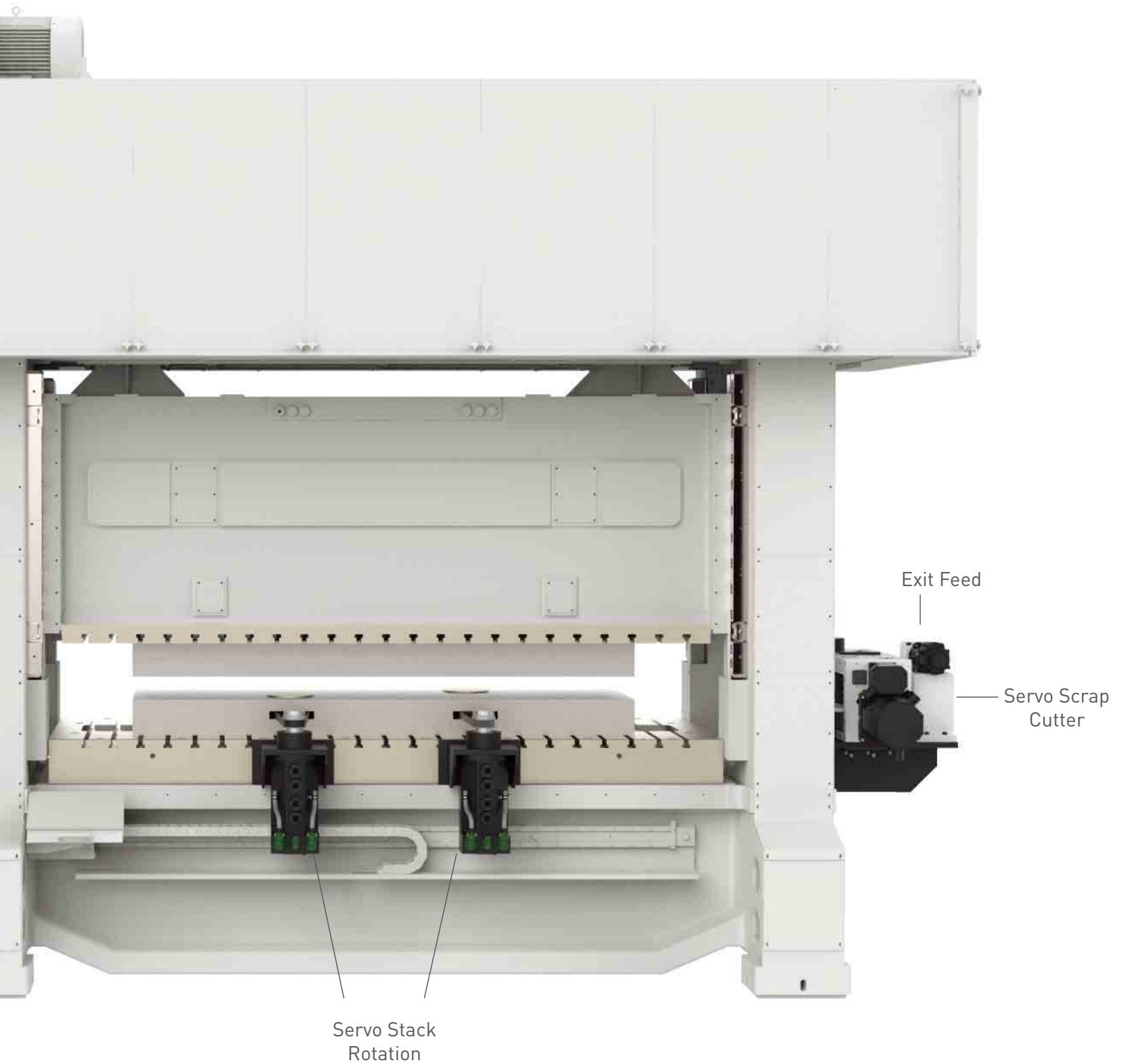

2 Quantum Servo Feeds deliver superior material feeding with integrated intelligence to detect problems before they enter the die space with on-demand job adaptability.

3 Quantum Servo Stack Rotation delivers integrated servo control and enables increased rotation accuracy and production speed through the use of our signature servo axis motors.

4 Quantum Servo Scrap Cutter delivers a system integrated and compact solution for scrap removal, increasing line reliability while decreasing the amount of required floor space.

Quantum Servo Feeds

The Industry Standard

With all of the functionality of a cam driven device, but without the fixed limitations. Quantum feeds continue to set the industry standard for material handling. Now with ACS, the Quantum also serves as an advanced diagnostic device capable of detecting and preventing expensive tool crashes, while delivering proven advantages:

- Superior material handling ability
- On-demand job adaptability
- Increased tool life
- Prevention of tool crashes
- Increased shop efficiency and reduced waste

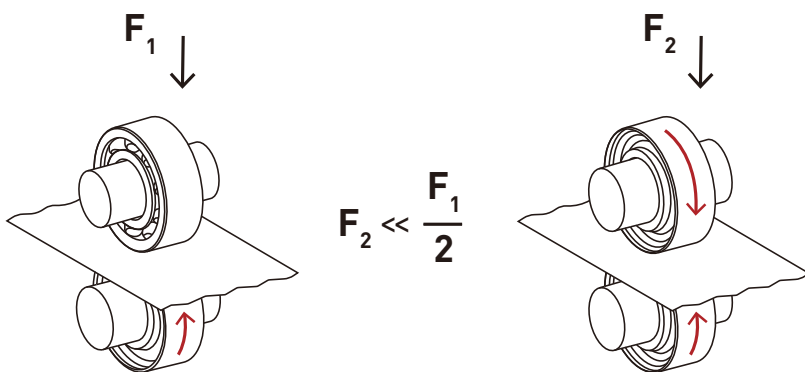

Standard Features

- Superior engineering & design
- Cast frame construction
- Powered upper & lower feed rolls
- Multi-axis coordinated servo control (max. 20)
- Electronic camming
- Full electronic adjustability
- Advanced & remote diagnostic capability
- Integrated tool protection
- Tool manager & parts database
- Integrated total system control

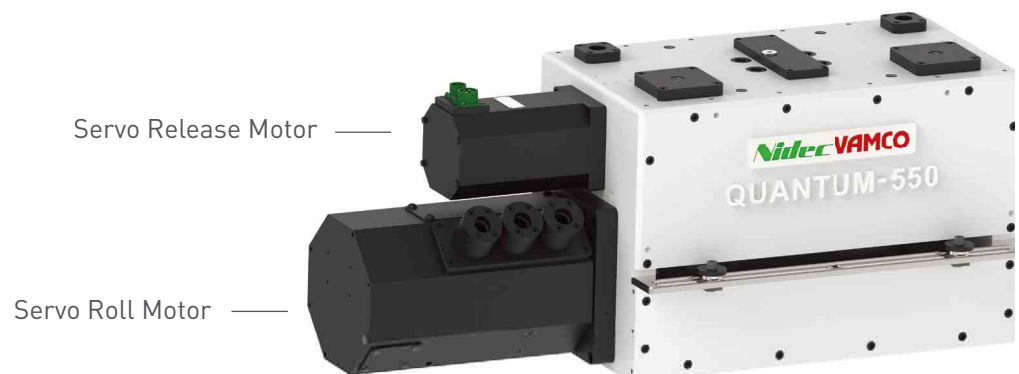

Standard Features

HMI Intelligence

- 430mm touchscreen display
- Press interlock status
- Real time feeding signatures
- On-screen Help
- USB Support

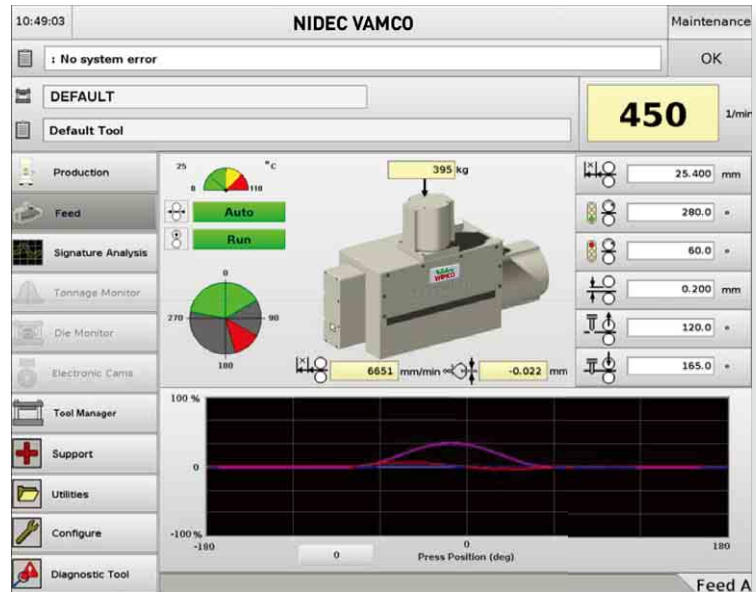

Programmable Database

- Feed length
- Feed angle
- Pilot release angle
- Material thickness
- Lift distance
- Grip pressure
- Multi-progression programming

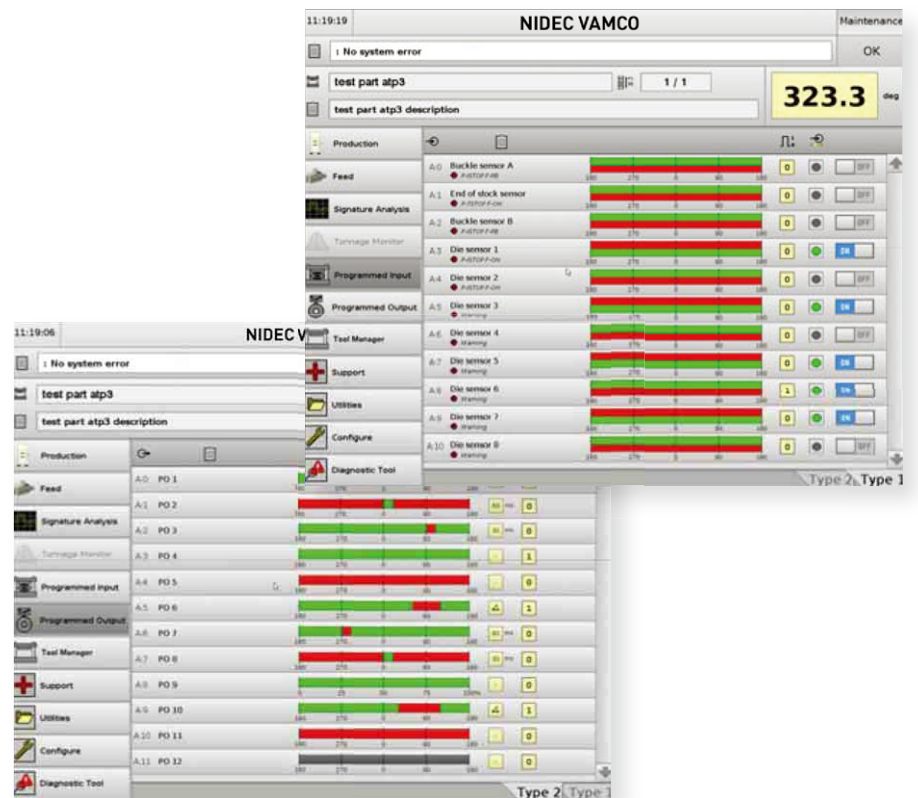

I/O Interface

- Selectable Inputs:
 - End of stock
 - Buckle detection
 - In-position
- Outputs:
 - Press position based
 - Feed progression based
 - Gagged tooling

Standard Features

Diagnostics and Tool Protection

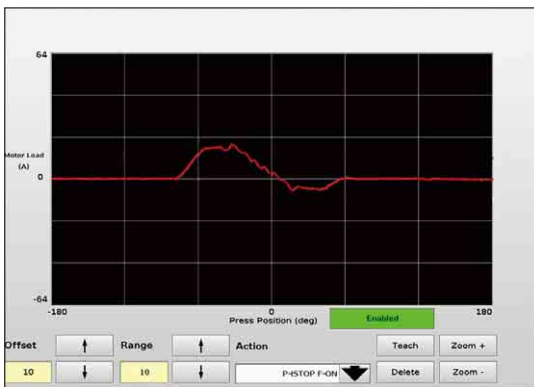

Digital Oscilloscope

Motor torque and velocity information is displayed in real-time for each advance of the stock material.

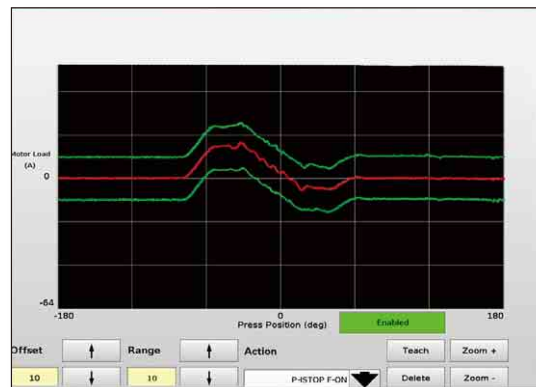

Signature Analysis

Generate user defined tolerance bands around a good feeding signature through an automated teaching process.

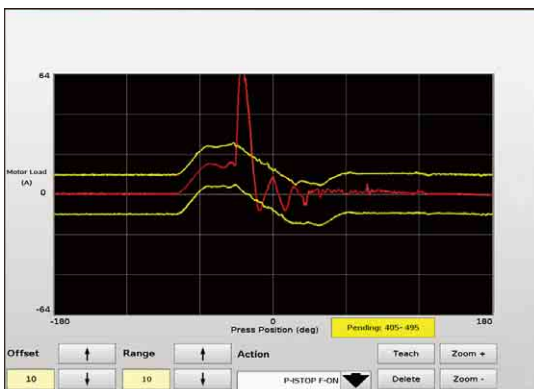

Die Jam Detection

Tolerance band violations indicate feeding obstructions within the tool.



Die Jam Correction

Reverse the stock material to a safe position while commanding a controlled press stop to prevent tool damage caused by partial feed lengths during a tool strike.

Automatic Pilot Timing Set-Up

Eliminate wasted time and increase tool life by allowing the Quantum ACS to determine and set its own pilot release timing through three simple steps:

1. Jog the stock material one complete feed length
2. Single stroke the press
3. Confirm the calculated value on the HMI and save in the part database

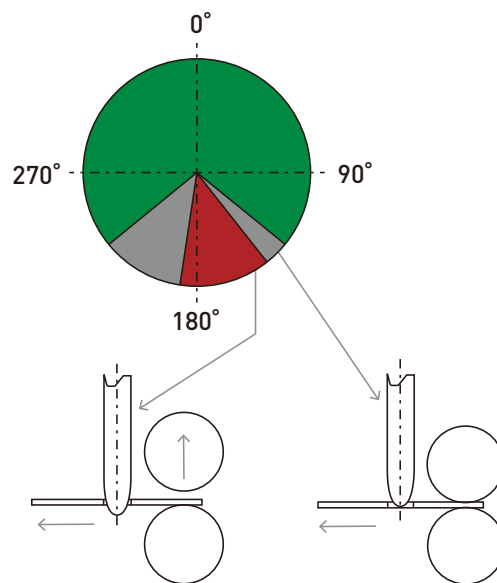

Press Shut Height Variation Compensation (PSHVC)

Eliminate improperly formed parts resulting from press slide penetration depth variation with changes in press speed. Simply program a minimum speed for press feeding and the Quantum ACS will only feed the stock material while the press is operating at a desirable slide speed.

Good part made with PSHVC

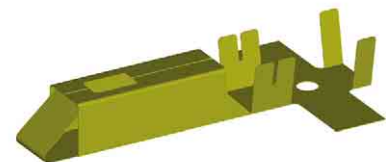

Bad part made without PSHVC

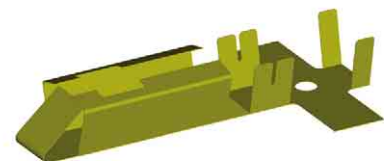

Standard Features

Lamination Stacking Controller (LSC)

The optional LSC module provides complete integrated process control over the functions associated with a complex motor core stamping process increasing production efficiencies and reducing costs with unnecessary additional control units.

Features Include:

- Stack height & feature control
- Double thickness sensing
- Stack separator
- Stack saver
- Conveyor control
- Thickness sensor interface

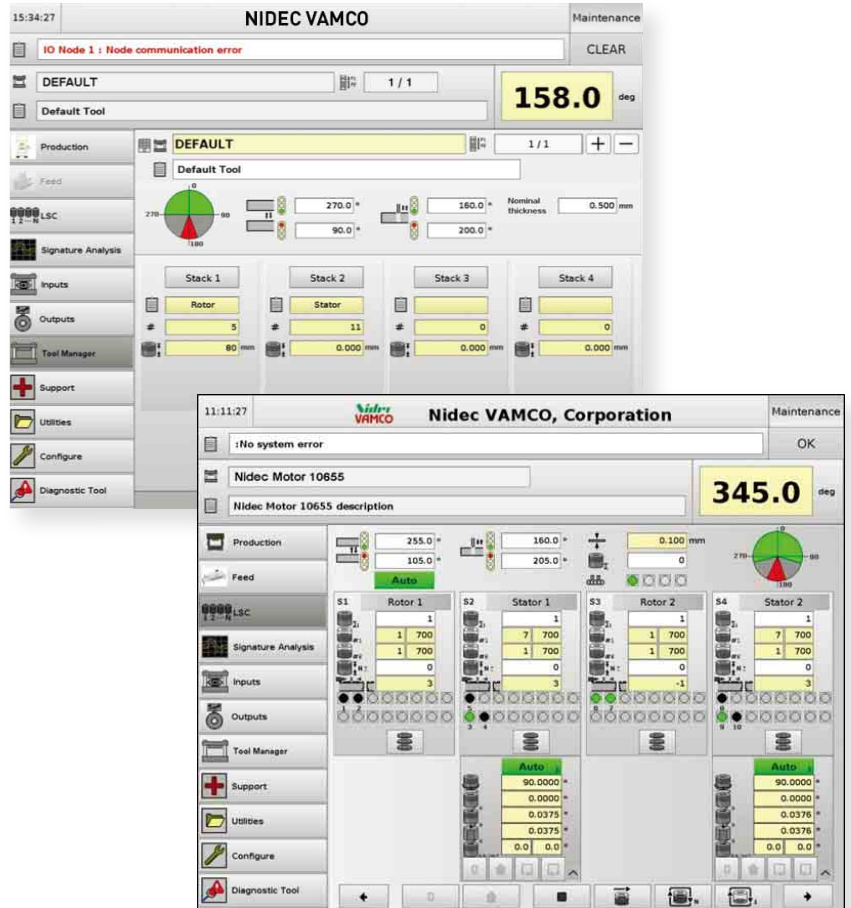

Optional Configurations

A single ACS control system tightly coordinates the motion of multi axis Quantum ACS feeding systems. Each axis follows a single press resolver ensuring the highest level of coordinated motion control.

Quantum DHS Systems

- Super High-Speed
- Two Motor Feed Roll Design
- Full Contact Feed Rollers



Quantum C-45 Two Strip System

- Two Independently Adjustable Feeds
- Two-Piece Electrical Connectors
- Independent Feed Settings



Push/Pull Systems

- Motor Core Laminations
- Soft Metals (Lead)
- Plastics

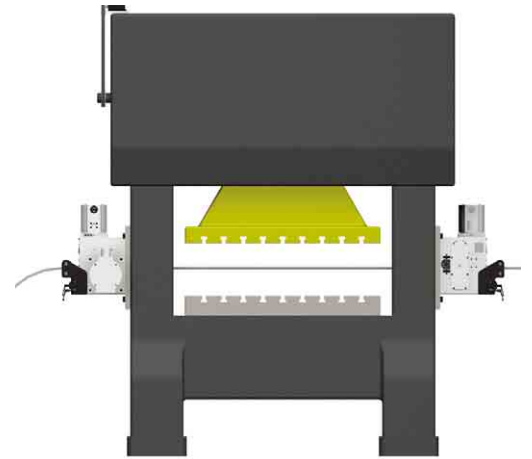

System Components

Quantum Servo Stack Rotation

A complete line of servo axis for motor core stack rotation designed specifically for high-speed indexing of high inertia systems.

Advantages Include:

- Integrated Servo Control
- Increased Production Speeds & Rotation Accuracy
- Designed for Vertical Mounting (Increased Life)
- Air or Water Cooled
- Signature Analysis
- Pilot Feature

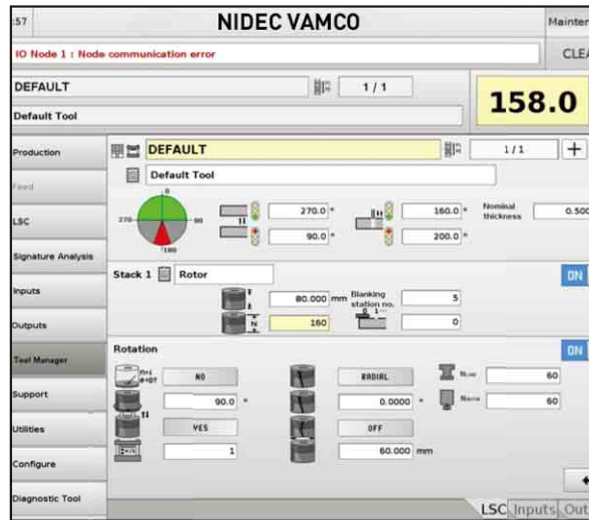

Quantum Active Loop Control

The Quantum active loop control reduces material acceleration forces by carefully coordinating the motion of the feed rolls with the rolls in a loop control unit.

Integrated Advantages Include:

- Reduced Loop Whip
- Increased Production Speeds
- Increased Feeding Accuracy
- Material Handling Integration
- Improved Safety (Operating & Threading Positions)

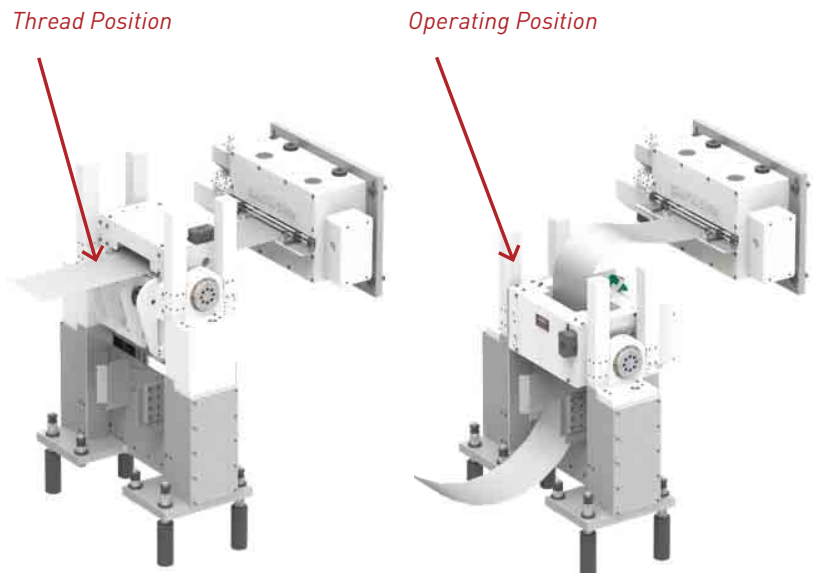

Quantum Servo Scrap Cutter

The Quantum servo scrap cutter provides a system integrated solution for waste removal, increasing line reliability while also decreasing the amount of required shop space.

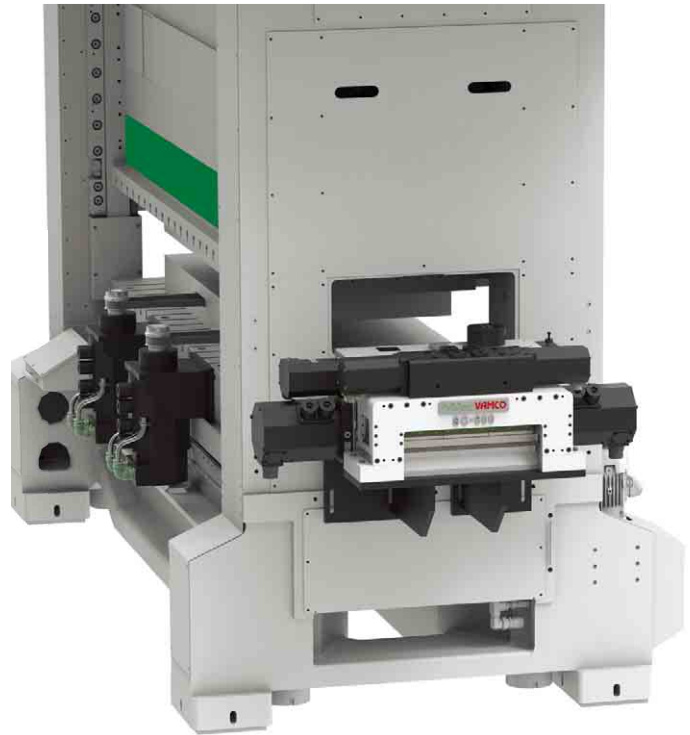

Electric Vehicle (EV) Full Product Integration

A total system solution: MINSTER EV Press + VAMCO EV Automation

Offering the world's fastest feeding system for thin laminations, Nidec Press & Automation has taken the power and technology of Minster presses and Vamco automation to offer a total system solution for EV laminations. Nidec branded press line components offer full OEM integration prior to installation, increasing operator ease of use, system integration uptime/value and reduction of required space.

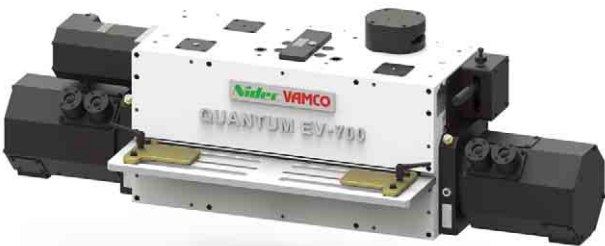

Reel

Straightener

Loop Control

Push/Pull Feeds

Press

Die & Stack Height Control

Stack Rotation

Scrap Cutter

Quantum EV System

The premiere solution for material feeding as thin as 0.20mm and available for complete OEM press integration.



Equipment Specifications

Quantum Servo Feeds

	MATERIAL WIDTH (MAX)	MATERIAL THICKNESS (MAX)	FEED ROLL WIDTH (STD)	FEED ROLL WIDTH (MAX)	INDEXES/MIN (MAX)
Quantum-100	100 mm	2.0 mm	25 mm	50 mm	2,200rpm/min
Quantum-C45	100 mm	2.0 mm	25 mm	25 mm	2,200rpm/min
Quantum-250*	250 mm	3.0 mm	50 mm	150 mm	1,500rpm/min
Quantum-350*	350 mm	5.0 mm	100 mm	200 mm	1,000rpm/min
Quantum-450*	450 mm	3.0 mm	100 mm	350 mm	1,000rpm/min
Quantum-550*	550 mm	5.0 mm	200 mm	400 mm	1,000rpm/min
Quantum-650*	650 mm	3.0 mm	250 mm	550 mm	1,250rpm/min
Quantum-EV-700*	700 mm	2.0 mm	550 mm	550 mm	800rpm/min
Quantum-750*	750 mm	5.0 mm	300 mm	600 mm	800rpm/min
Quantum-EV-850*	850 mm	2.0 mm	700 mm	700 mm	700rpm/min

* Also available in HS and DHS configurations for higher material through-put.

"If it is almost right, it is wrong."

Patrick J. Gentile, Founder
1917-1996

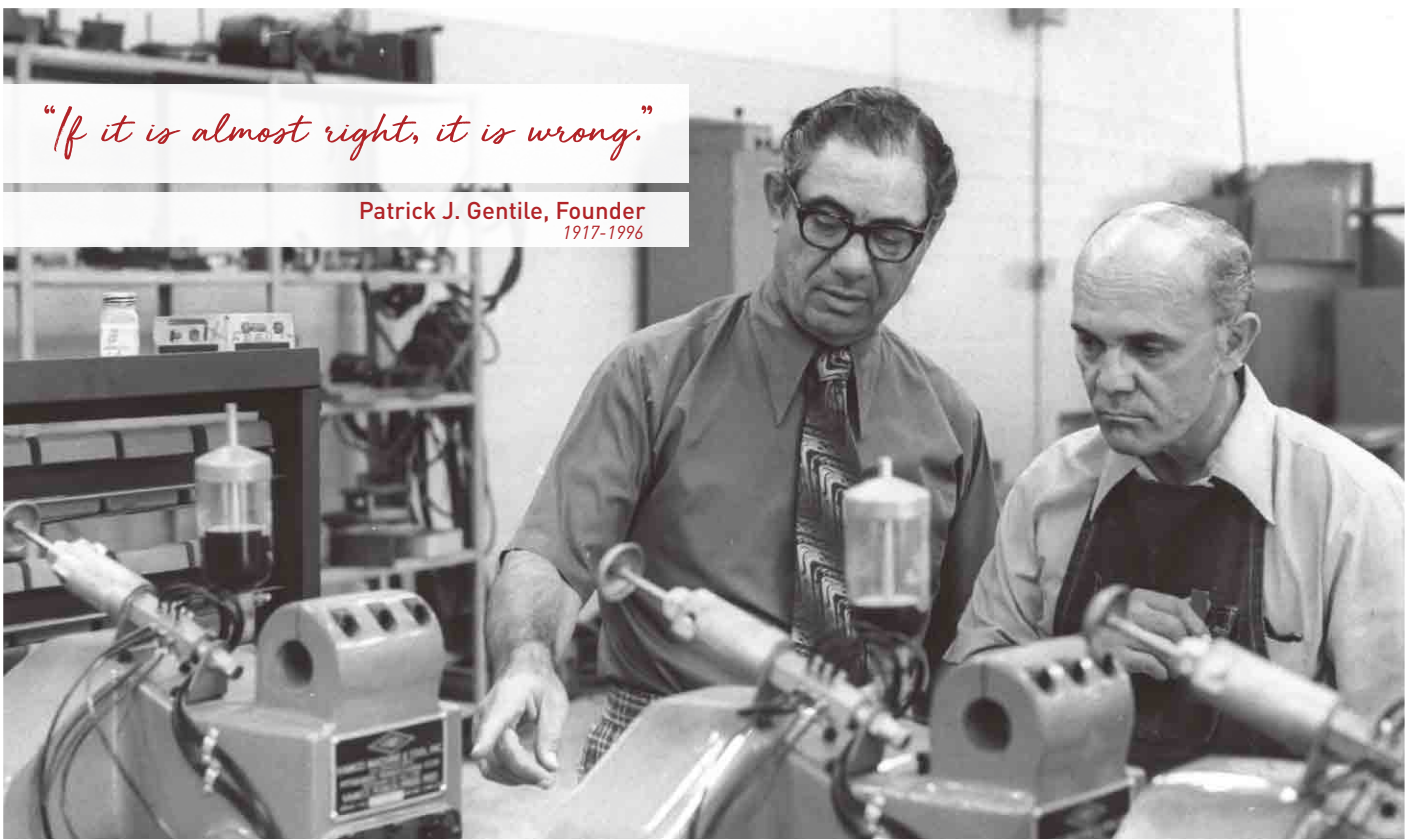

Quantum Active Loop Control

	MATERIAL WIDTH (MAX)	MATERIAL THICKNESS (MAX)	FEED ROLL WIDTH (MAX)	SPEED (MAX)
Quantum-ALC-250	250 mm	2.0 mm	150 mm	125 m/min
Quantum-ALC-450	450 mm	2.0 mm	350 mm	110 m/min
Quantum-ALC-650	650 mm	2.0 mm	550 mm	100 m/min

Quantum Stack Rotation Motors

	AIR COOLED	WATER COOLED
5 kW	STD	Optional
8 kW	STD	Optional
20 kW	STD	Optional
30 kW	STD	Optional

Quantum Servo Scrap Cutter

	CUTTING WIDTH (MAX)	PRESS FORCE (MAX)	TOOL AREA	INDEXES/MIN (MAX)
Quantum-SC-600	600 mm	20 kN	850mm x 225mm x 185mm	500/min



One Brand: A World of Resources

Nidec Press & Automation is the full service pressroom provider of choice for businesses in more than 90 countries and on six continents. Comprised of leading press room product brands, we ensure a complete offering of machinery, services and technology to meet your exact needs, enabling you to rely on one source.

Discover the freedom to achieve, to maximize and to drive your operation to exceed your goals. At Nidec Press & Automation, your success is the core of our focus and how we design our solutions to meet the rigid needs of the metal forming industry.

Choosing to work with us means you gain a constant resource with a global footprint, the brightest minds behind our solutions, and backed by regionally based OEM support ready to work as a natural extension of your team.

**Our promise to you is simple:
We're with you whenever and wherever
business takes you.**



MACHINERY

- Turn Key Systems
- Individual Components
- System/Tech Upgrades
- i4.0 Software Upgrades
- Integrated Controls

METAL FORMING PRESS APPLICATIONS

- Mechanical
- Servo
- Transfer
- High-Speed & Electrical
- Electrical Vehicle (EV)
- Lamination
- Container Cupping
- Container End-Conversion
- Container Shell
- Gap/D-Frame

AUTOMATION

- Press Tending / Robotics
- Integrated Transfer
- Systems
- High Speed Servo Feeds
- High Speed Gripper
- Feeds
- Heavy-Duty Coil Lines

GLOBAL SERVICE NETWORK

- Field Service
- Emergency Response
- Technical Service & Support
- OEM Replacement Parts
- Machine & Component Remanufacturing
- Technical Training



One Brand: A World of Resources

A single source solution that will help you find the efficiencies you want — all from the products, services and technology of Nidec Press & Automation.

nidecpa.com